

2000AXT

3-Way Speaker

SPECIFICATIONS

ACOUSTIC & ELECTRICAL SPECIFICATIONS:

- Nominal Impedance: 8 ohms
- Power Rating: 20 to 200 watts RMS
- Crossover Frequencies: 500Hz and 5,000Hz
- Frequency Response: 30Hz-21,000Hz +/-3.5dB

PHYSICAL SPECIFICATIONS:

- 1x - Walsh WTL Tweeter
- 1x - EMIT Tweeter
- 1x - 4" (10.1cm) Midrange
- 1x - 10" (25.4cm) Q-Woofer
- Dimensions: 27-3/4"H x 20"W" x 14"D
63.5cm(H) x 36.8cm(W) x 30.5cm(D)
- Cabinet: Not Sold
- Grille: NLA
- Crossover: NLA
- Tweeter Level Control: #145-0103
- Logo: #716-0138

PRODUCTION HISTORY

- Introduced in 1973
- Discontinued 1978
- Original Retail Price: \$600.00/pair

TECHNICAL INFORMATION

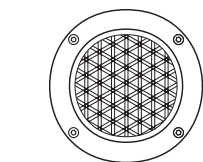

SUPER TWEETER
#902-0060

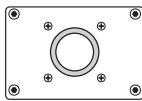

TWEETER
#902-0129
DIAPHRAGM
N/A

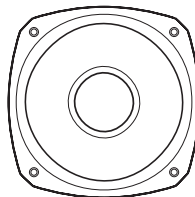

4-1/2" MIDRANGE NLA
Substitute #902-0074

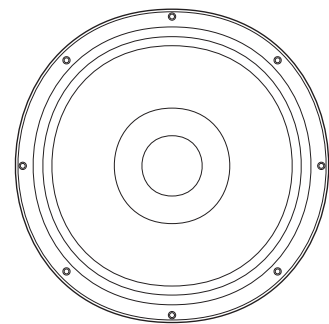

12" WOOFER NLA
Substitute #902-1187

